

# ShowerDrain C - Slot design grate plain edge channel

**Plan View**

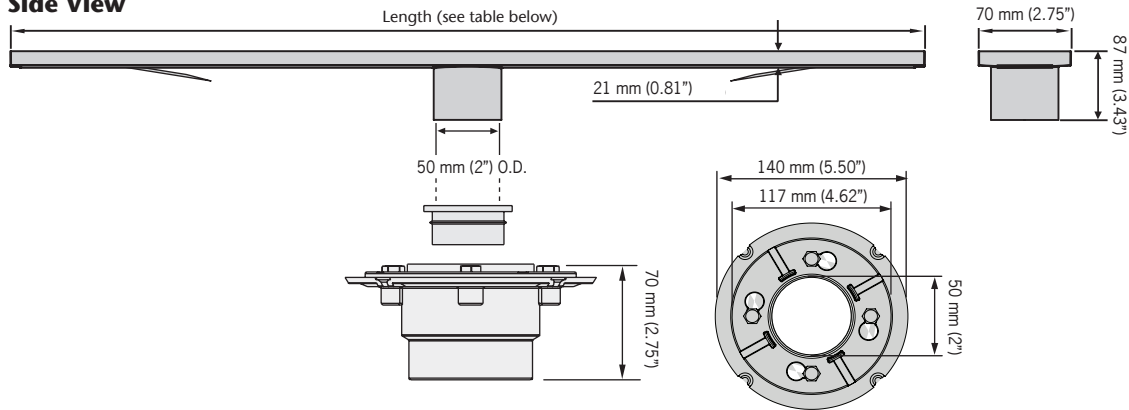

**Side View**



**Product Table**

Part No.	Length mm (inches)	Width (mm) inches	Weight kg (lbs)	Intake area sq. cm (sq. in)
<b>296044</b>	<b>686 (27)</b>	<b>70 (2.75)</b>	<b>1.2 (2.7)</b>	<b>67.9 (10.5)</b>
<b>296047</b>	<b>886 (34.9)</b>	<b>70 (2.75)</b>	<b>1.4 (3.3)</b>	<b>88.2 (13.7)</b>
<b>296050</b>	<b>1186 (46.7)</b>	<b>70 (2.75)</b>	<b>1.9 (4.2)</b>	<b>118.7 (18.4)</b>

**Specification Clause**

**General**

The ACO ShowerDrain C plain edge channel and grate system shall be stainless steel grade 304 manufactured by The ACO Group and, supplied by ACO Systems, Ltd. Canada. The surface treatment applied after the manufacturing process to prevent corrosion shall be pickle passivation. Grate shall be Slot design.

Shower channels shall be 70 mm (2.75") wide and 686 mm (27.0")/886 mm (34.9")/1186 mm (46.7")\* in length. Outlet spigot (O.D.) diameter shall be 50 mm (2.0)".

**Waterproofing and plumbing connection**

The PVC membrane coupling (provides connection to S/S spigot of shower channel and plumbing pipe system) shall be supplied by ACO Systems, Ltd. The PVC drain body will provide secondary drainage at membrane level and clamping ability for waterproofing membrane (supplied by others).

**Installation**

ACO recommends checking local plumbing codes prior to installation. The system shall be installed in accordance with the manufacturer's instructions and recommendations.

**ACO Systems, Ltd.**

1-2880 Brighton Rd.  
Oakville, ON L6H 5S3  
Tel: (905) 829-0665  
Fax: (905) 829-2908

**Electronic Contact:**

Eml: info@acocan.ca  
Web: www.acoshowerdrain.ca



©December 2018, ACO Systems, Ltd. This information is believed to be accurate but it is not guaranteed to be so. We cannot assume liability for results that buyer obtains with our product since conditions of use are beyond the control of the company. It is the customer's responsibility to evaluate suitability and safety of product for his/her own use. ACO Systems, Ltd. Reserves the right to change the products and specification without notice.

ACO Specification Information

